

### 200D Idle Adjustment Change

This TSB introduces a new idle adjustment design for the 200D Carburetors/Mixers. The original idle was adjusted using a socket head screw shown below (left.) The new design uses a 5/16" or metric 8mm hex key shown below (right) and will accept a tamper resistant plug to comply with emission regulations.

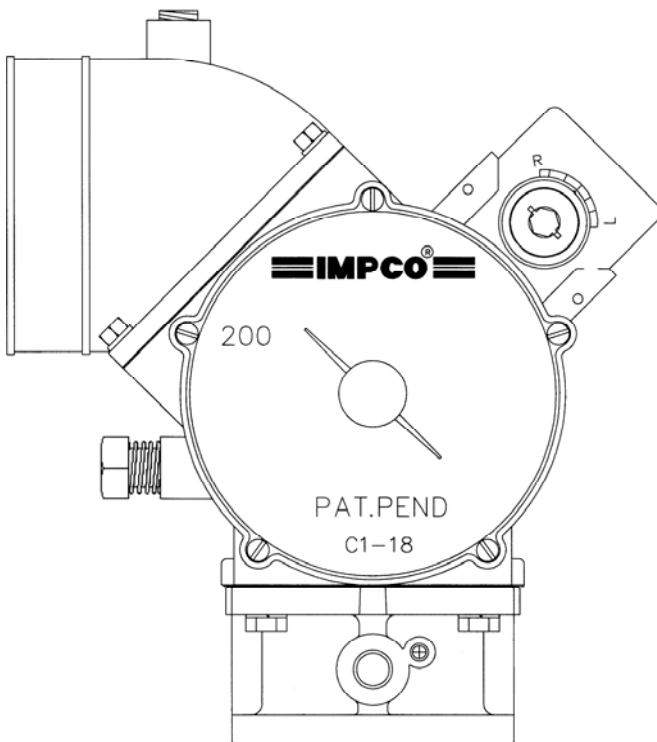

*Original design, featuring a hex idle adjustment screw.*

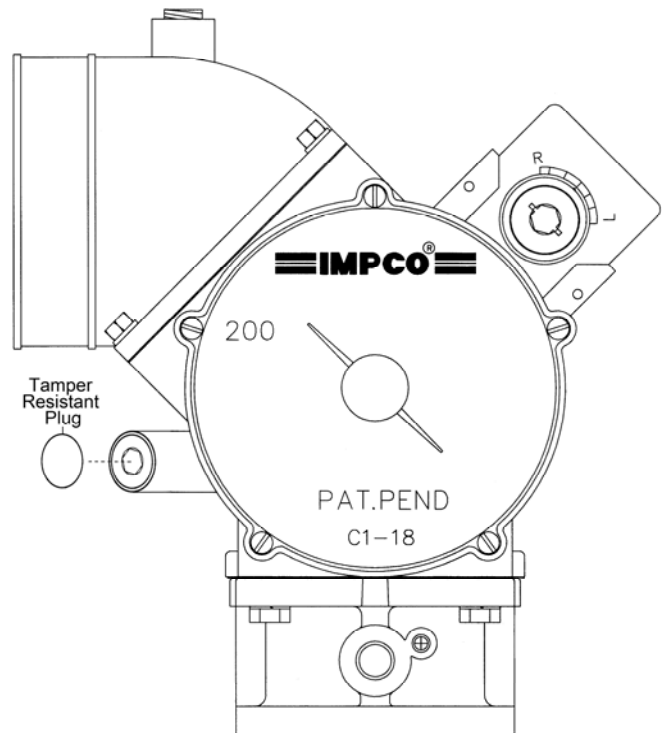

*New design, featuring a tamper resistant idle adjustment plug.*

The Tamper Resistant Plug (part number P3-17956-20) must be purchased separately.