

### New IMP Series Regulator

This TSB introduces part number IMP53-50981-001, an improved version and direct replacement for the current IMP53 series low pressure regulator. The IMP53-50981-001 is manufactured by IMPCO Technologies, Inc. and is UL recognized. Product enhancements include: 1/8" NPT diagnostic test ports on the inlet and outlet, an additional vent port, tamper resistance capability (with the installation of optional pressure adjustment plug, part number P3-17956-18), and a new satin aluminum finish. Part number IMP53 will no longer be available and is permanently replaced by part number IMP53-50981-001.

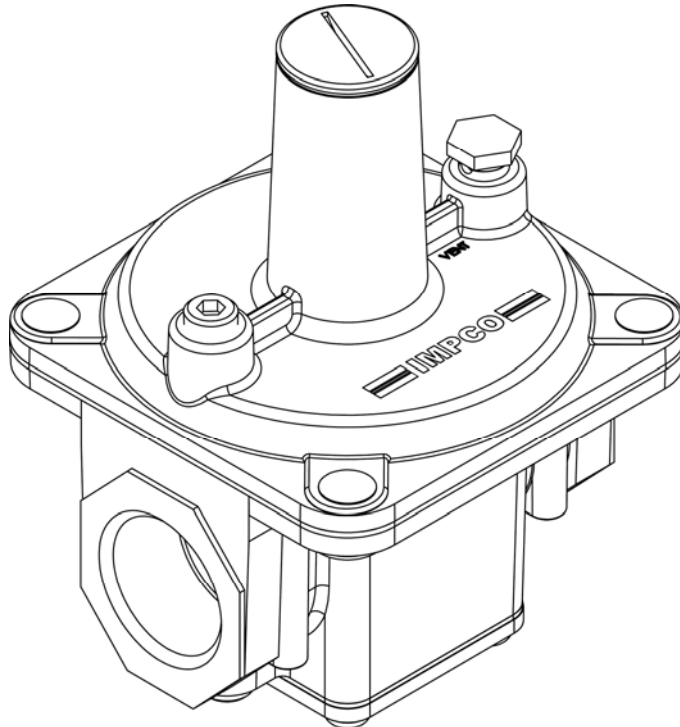

**IMP53-50981-001**

Fuel Type ..... LPG Vapor or Natural Gas  
 Inlet Pressure  
     (maximum) ..... 20" w.c. (5.0 kPa)  
     (emergency exposure limit) ..... 3.0 psi  
 Nominal Outlet Pressure ..... 3.0" to 6.0" w.c. (0.75 to 1.5 kPa)  
 HP/kW ..... 180hp (134.2kW)  
 Operating Temperature Range ..... -40°F to +250°F (-40°C to +121°C)  
 Applications ..... Stationary, Industrial  
 Certification ..... UL Recognized (file #MH46841) at 20" w.c. (5.0 kPa)

Part#	Overall Length	Overall Width	Overall Height	Inlet & Outlet NPT	Vent Boss Diameter (2X)
IMP53-50981-001	101.09 (3.98")	98.55mm (3.88")	137.92mm (5.43")	1"	1/8"

