

HPR 3600

HEAVY DUTY PRESSURE REGULATOR WITH INSTALLATION HARDWARE

Key Features

High pressure single stage regulator for compressed natural gas with working inlet pressure up to 25MPa is available with optional manifold reference pressure barb for improved response. Engine coolant barbs are now expanded to offer 3/8" or 5/8" in both straight and angled.

- Proven design with over 30 years of in service history.
- Optional MAP reference barb.
- Certified to ECE R110 and ISO 15500.
- Built in fuel filter.
- 3/8" or 5/8" coolant barbs, straight or angled.



SPECIFICATIONS

HPR 3600	
GENERAL INFORMATION	
APPLICATION	High pressure single stage regulator
DESIGN	Single stage regulator heated by coolant
FUEL TYPE	High Pressure Natural Gas (Validated with G20 and G25 CNG)
PERFORMANCE	
WORKING PRESSURE	25 MPa (3,600 psig)
BURST PRESSURE	> 65 MPa
MINIMUM INLET PRESSURE	1.17 MPa
TYPICAL OUTLET PRESSURE	1.1 MPa (factory options available)
OUTLET FLOW RATE	Up to 20 g/s
WORKING TEMPERATURE	-40°C to 120°C (-40°F to 248°F)
PRESSURE RELIEF VALVE	2.76 MPa
FILTER (REPLACEABLE)	40 µm, 99% efficiency
LEAKAGE	<0.25 standard cc/min Helium, external (<0.25 standard cc/min Helium, internal)
HEATER CIRCUIT	
MEDIA	Water / Ethylene Glycol Mixture
FLOW DIRECTION	Bi directional
APPROVALS	
CERTIFICATIONS	ECE R110, ISO 15500-2012

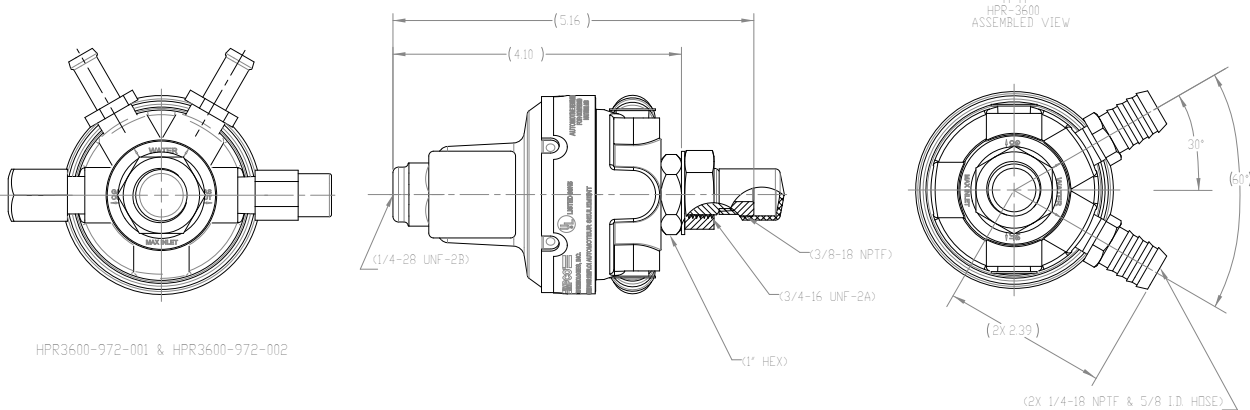

1. IMPCO Technologies Inc. Canada
 2. IMPCO Technologies Inc. Santa Ana California - IMPCO Technologies Inc. Canada - IMPCO Technologies BV Europe
 3. IMPCO Technologies Inc. Santa Ana California - IMPCO Technologies BV Europe

300023_REV D
 ©IMPCO Technologies Inc. All rights reserved.
 All information is subject to change without notice.
 Images for illustration purposes only, may not reflect configuration provided.



ISO/TS 16949:2009 registered¹
 ISO 9001:2008 registered²
 ISO 14001:2004 registered³