



MODEL PJ REGULATOR/CONVERTER

REPAIR KIT INSTRUCTIONS

Important: Any maintenance, service or repair should be performed by trained and experienced service technicians. Proper tools and equipment should be used to prevent injury to the servicing technician, property or system components. Service repairs should always be performed in a safe environment and the technician should always wear protective clothing to prevent injury.

The IMPCO PPI-112 repair kit instructions will provide the technician information to successfully repair the Model PJ regulator converter. Always inspect the major casting pieces for damage, corrosion or cracks before attempting a service repair. Be sure the repair kit part number you are using is correct for the regulator being serviced.



Model PJ Converter



WARNING

Do not use Teflon tape to seal any fuel fittings. Failure to follow this warning may cause the regulator to leak internally, possibly resulting in serious injury and/or property damage and may void any warranty coverage.

REPAIR KIT PART NUMBER

Part #	Description
RK-PJ	Repair Kit Model PJ, Hydrin Diaphragm



MODEL PJ REGULATOR/CONVERTER

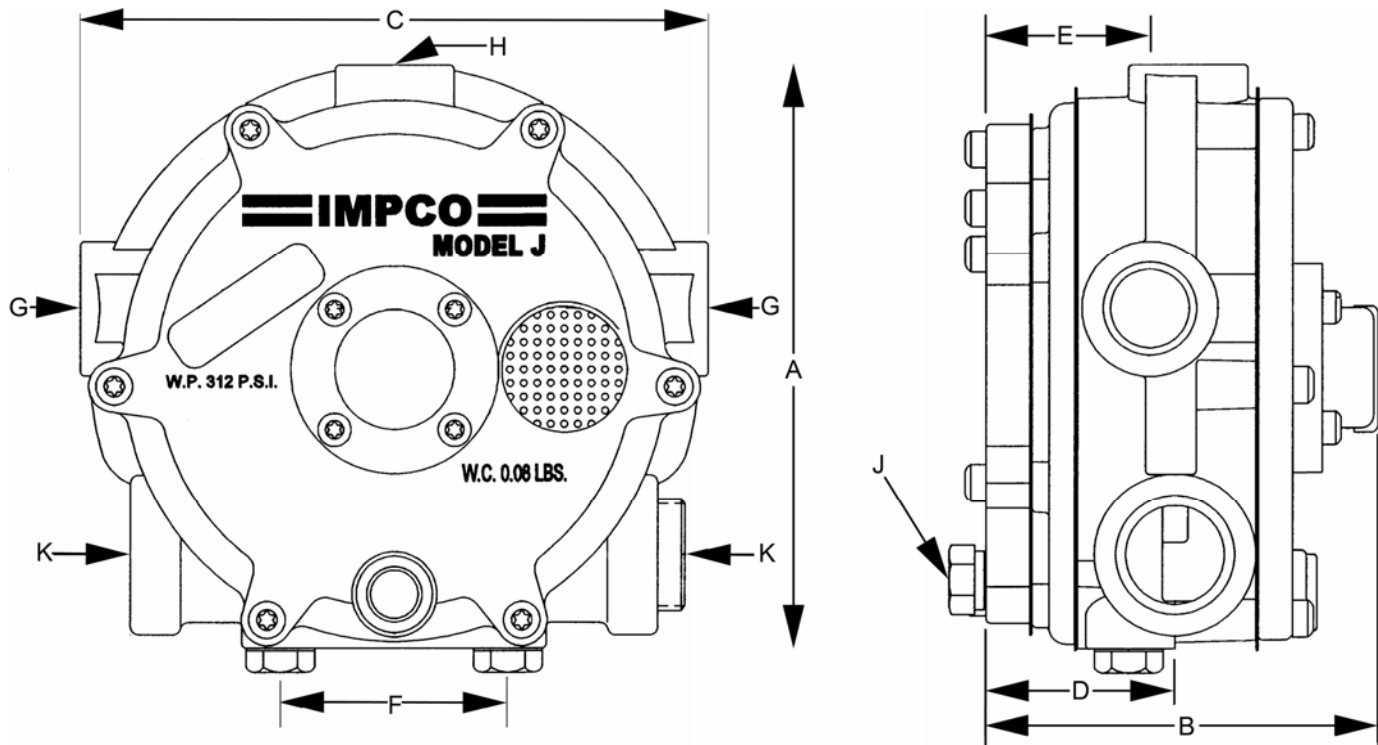

A	B	C	D	E	F	G	H	J	K
			BACK OF CONVERTER TO	BACK OF CONVERTER TO CTR. OF	MOUNTING HOLES CTR. TO CTR.	COOLANT INLET AND OUTLET	LIQUID FUEL INLET	PRIMARY TEST PORT	VAPOR FUEL OUTLET
OVERALL HEIGHT	OVERALL DEPTH	OVERALL L WIDTH	CTR OF VAPOR FUEL OUTLET	WATER OUTLET		(NPT)	(NPT)	(NPT)	(NPT)
109.98mm (4.33")	80.00mm (3.15")	118mm (4.63")	37.8mm (1.49")	26.42mm (1.04")	41.3mm (1.63")	3/8"	1/4"	1/8"	1/2"

MODEL	SECONDARY DIAPHRAM	OUTLET PRESSURE
PJ	AD1-26-2 (Hydrin)	Nominal +5.0" w.c.

MODEL PJ SERIES CONVERTERS

ITEM #	PART #	DESCRIPTION
1	S7-4	Screen, Vent
2	S1-15265-003	Screw, 8-32 x 7/8" Torx style (6)
3	C1-25824	Cover Assy Secondary
4	AD1-26-2*	Diaphragm ass'y, secondary
5	S1-17460-001	Screw, 8-32 x 1/2" Torx style
6	L1-37*	Lever, Secondary
7	P1-8	Pin, Secondary Fulcrum
8	S4-27*	Seat, Low Pressure
9	S2-99	Spring, secondary 4"
10	AB1-15869	Body Assy
11	S1-5	Screw, Hex Head 1/4"-20
12	G1-85*	Gasket, Body Plate
13	P1-14*	Pin, Secondary Fulcrum
14	P2-26	Plate, Converter Body
15	P3-13	Plug, 1/8" NPT, hex head
16	S2-98	Spring, Primary Reg
17	S4-16*	Seat, Primary Reg
18	AD1-22*	Diaphragm Assy, Primary
19	C1-93	Cover, Primary
20	S1-15265-005	Screw, 8-32 x 1-1/8" torx style (7)
21	H3-3	Housing, Spring
22	S1-101	Screw 6-32 x 5/16" Panhead
23	G1-84*	Gasket, Spring Housing
24	P3-14	Plug, 1/2"-14 NPT

NSS = Not Serviced Separately

* Included in repair kit

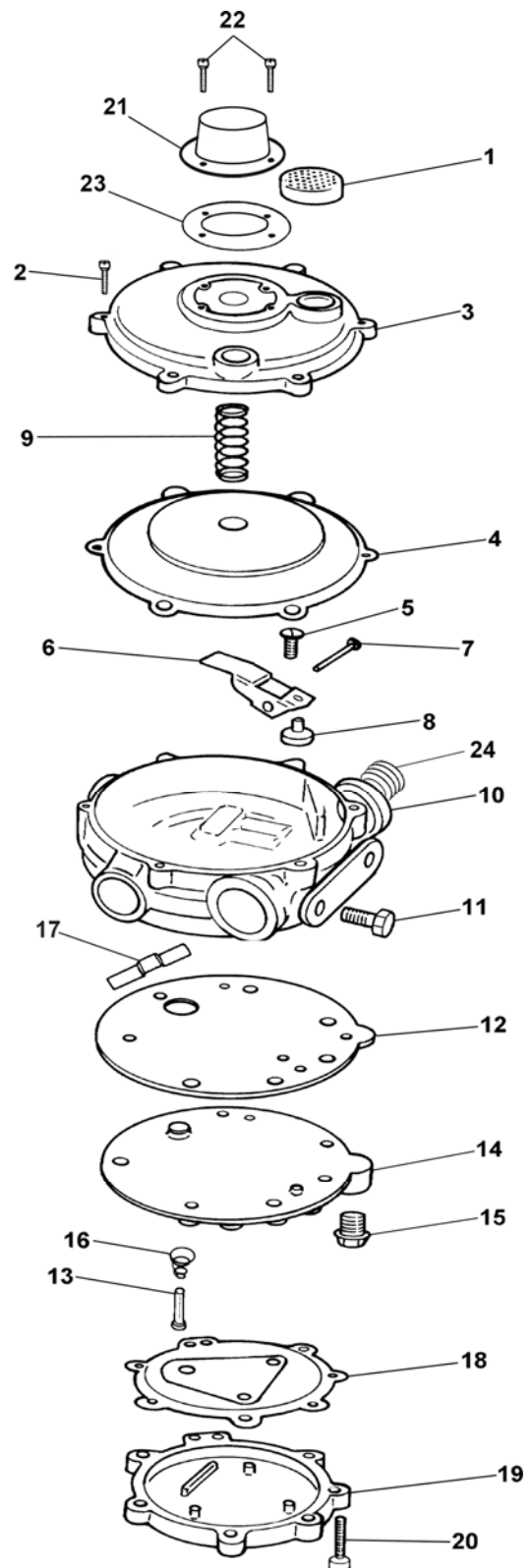

REBUILD INSTRUCTIONS



1. Under normal conditions, installation of a complete Model PJ Repair Kit should be necessary only at the time of a major engine overhaul or when the converter has been out of service for an extended period of time. Each kit includes the gaskets, diaphragms, and seats necessary for servicing.



2. Remove the 6 screws (2) from the secondary cover assembly (3).

NOTE: Identify the type and location of screws removed (i.e. Torx) in all steps to ensure the same type and size screws are returned to the correct locations during reassembly.



3. Loosen the secondary cover (3) by tapping around the circumference with a plastic screw driver handle or rubber mallet.



4. Remove the secondary cover (3) and secondary diaphragm (4) as a unit. Note the secondary lever (6) protruding through the metal tab slot of the secondary diaphragm. Slide the cover and diaphragm toward the gas inlet to free the lever from the slotted tab of the diaphragm. Gently remove this assembly to prevent bending the lever. Remove diaphragm from cover and spring. The secondary spring (9) will be found between the cover and diaphragm.



5. Remove the four screws (22) securing the spring housing (21).



6. Remove the spring housing (21) and gasket (23).



7. Remove screw (5), the secondary lever (6) and the fulcrum pin (7) and set aside for the reassembly.



8. Turn the converter over. Remove the seven screws (20) and lift off the primary cover (19).

9. Remove the primary diaphragm (18).



10. Remove the primary valve pin (13) and spring (16).



11. Remove cover plate (14) and the gasket (12).



12. Remove the gasket (12) from the cover plate (14).
Clean cover plate as needed to ensure a good seal with a new gasket. Do not use harsh solvents such as brake or carburetor cleaner on any of the non-metallic components as they will damage the materials.





13. Remove the primary seat (17). Clean covers, body and metal parts as necessary with a safety solvent as needed and allow to dry prior to reassembly. Do not use harsh solvents such as brake or carburetor cleaner on any of the non-metallic components as they will damage the material.



14. Install new primary regulator seat (17).



15. Set new primary gasket, (12), from the kit on the converter cover plate (14). The gasket will only fit one way (screw hole spacing prevents improper orientation of the diaphragm). The primary pressure hole in the gasket must line up with the hole in the body cover plate.

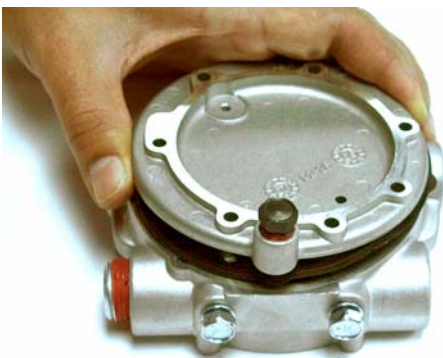

16. Place the cover plate (14) and gasket (12) on the converter body and align the cover screw holes.



17. Insert the new primary valve pin (13) through the spring (16) and insert into the cover (14) with the larger diameter end of the spring resting against the plate.



18. Set the primary diaphragm (18) in place on the converter body cover plate (14). Line up the screw holes to the cover plate.



19. Carefully place the primary cover (19) over the diaphragm (18). Hand-thread the screws (20) through the cover and cover plate into the converter body.



20. Tighten the screws (20) to 22-28 in-lb. (2.5-3.2 N•m) in a criss-cross pattern.

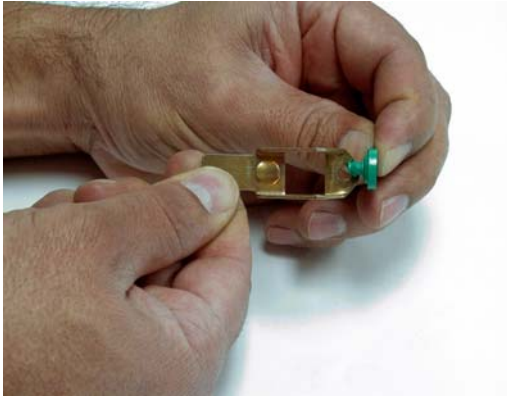

21. Assemble the new secondary seat (8) and new secondary lever (6) by inserting the seat retaining tip to the end opening of the lever as shown. Be sure the new seat snap-locks into place.

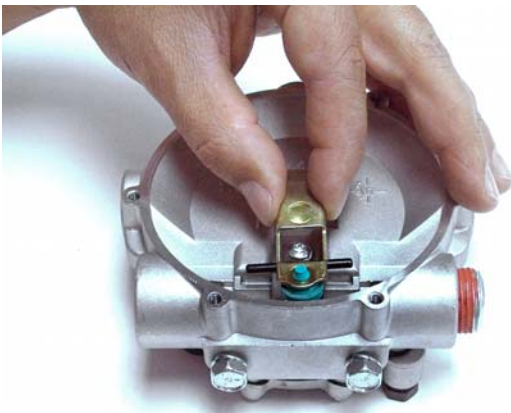

22. Place the lever pin (7) and lever (6) into place.

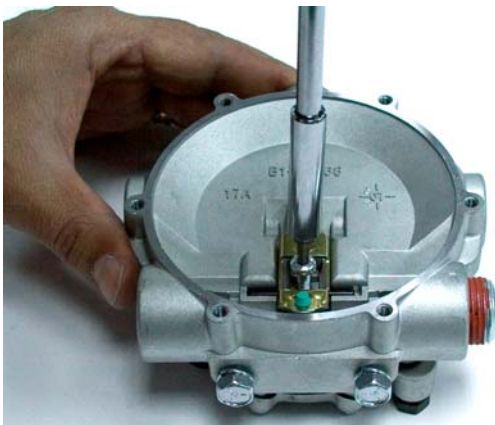

23. Hold the lever assembly in place and fasten in place with the screw (5).



24. Tighten the screw (5) to 30 +/-3 in.-lbs. (3.39 +/- 0.34 N•m).



25. The secondary lever should be $3/32$ " below the level of the body. Use a straight edge to measure. Remove and gently bend the lever if necessary to obtain the correct height.

 **Note:** Bending the lever while installed may result in damage to the seat. Remove from the body, bend, reinstall, then check height.

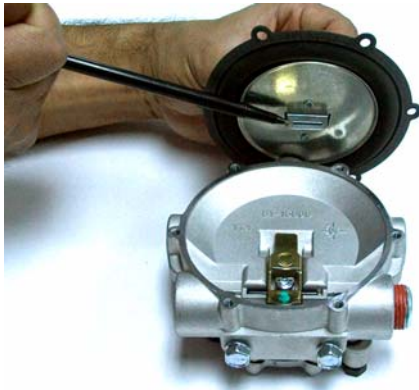

26. Align the secondary diaphragm (4) to the lever (6) as shown. The end of the lever must protrude through the tab slot on the bottom of the new diaphragm after installation. The cut-out area (shown in photo) from which the tab is punched should be located toward the gas inlet port.



27. Place new gasket (23) and spring cover (21) on the secondary cover (3).



28. Place screws (22) on cover and tighten to 9 ± 2 in-lbs. (1 ± 0.23 N•m)

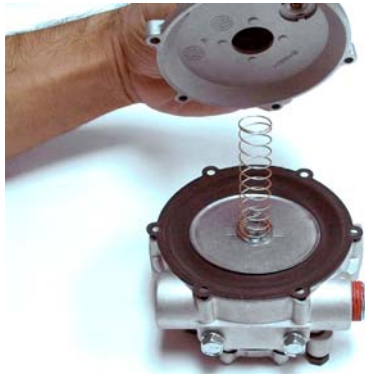

29. Place secondary spring (9) on the diaphragm (4), making sure it is properly seated on the spring perch. Place the secondary cover (3) on top with the spring inserted into the spring housing.

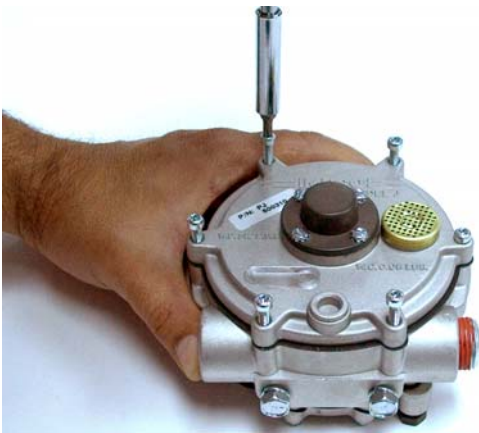

30. Install the secondary cover (3) with the six screws (22).



31. Tighten the screws (2) in a crisscross pattern to 22-28 in-lb. (2.5-3.2 N•m), to complete the installation of the repair kit components.



32. Attach an air hose fitting to inlet at the top and thread the special bleed plug (shown held on the right) and the two brass fittings (shown on the left). Both the special bleed plug and brass fittings are included in IMPCO Test Kits ITK-1 and ITK-4.

Note: The special bleed plug has a hole to allow the passage of air and is different from the solid plug (24).

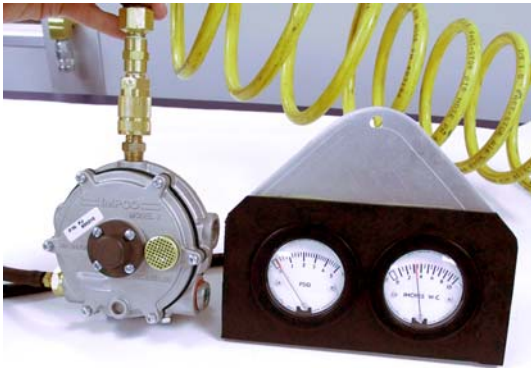

33. Attach a 100 psi air pressure hose to the regulator "IN-LET" fitting. Connect a water column gauge to the brass fitting(s) to measure the output pressure. Check the spring housing (21), body plate (14) and both covers (3 and 19) for leaks using a liquid leak detector solution. The pressure should measure 5" w.c. or less. If the pressure exceeds 5" w.c., the rebuild has failed and the regulator must be replaced.



34. Remove air hose fitting, brass fittings and replace the special bleed plug with the plug (24). Torque 2 to 3 turns past finger tight. The rebuild is now complete.



WARNING:

**IMPROPER INSTALLATION OR USE OF THIS PRODUCT MAY CAUSE
SERIOUS INJURY AND/OR PROPERTY DAMAGE.**

SERVICE TECHNICIANS AND USERS

SHOULD CAREFULLY READ AND ABIDE BY THE PROVISIONS SET FORTH IN NATIONAL FIRE PROTECTION ASSOCIATION PAMPHLET #37 FOR STATIONARY ENGINES, #52 FOR CNG VEHICULAR FUEL SYSTEMS OR #58 FOR LPG SYSTEMS.

INSTALLERS

LPG INSTALLATIONS IN THE UNITED STATES MUST BE DONE IN ACCORDANCE WITH FEDERAL STATE OR LOCAL LAW, WHICHEVER IS APPLICABLE AND NATIONAL FIRE PROTECTION ASSOCIATION PAMPHLET #58, STANDARD FOR STORAGE AND HANDLING OF LIQUEFIED PETROLEUM GASES TO THE EXTENT THESE STANDARDS ARE NOT IN VIOLATION WITH FEDERAL, STATE OR LOCAL LAW.

IN CANADA

REFER TO CAN/CGA PROPANE INSTALLATION CODES.

CNG INSTALLATIONS IN THE UNITED STATES

MUST BE DONE IN ACCORDANCE WITH FEDERAL STATE OR LOCAL LAW AND NATIONAL FIRE PROTECTION ASSOCIATION PAMPHLET #52, COMPRESSED NATURAL GAS (CNG) VEHICULAR FUEL SYSTEMS TO THE EXTENT THESE STANDARDS ARE NOT IN VIOLATION WITH FEDERAL, STATE OR LOCAL LAW.

IN CANADA

REFER TO CAN/CGA CNG INSTALLATION CODES.

LPG AND/OR NATURAL GAS INSTALLATIONS ON STATIONARY ENGINES

MUST BE DONE IN ACCORDANCE WITH FEDERAL, STATE OR LOCAL LAW AND NATIONAL FIRE PROTECTION ASSOCIATION PAMPHLET #37, STATIONARY COMBUSTION ENGINES AND GAS TURBINE ENGINES, TO THE EXTENT THESE STANDARDS ARE NOT IN VIOLATION WITH FEDERAL, STATE OR LOCAL LAW. FAILURE TO ABIDE BY THE ABOVE WILL VOID ANY IMPCO WARRANTY ON THE PRODUCTS AND MAY CAUSE SERIOUS INJURY OR PROPERTY DAMAGE.

DUE TO THE INHERENT DANGER OF GASEOUS FUELS THE IMPCO PRODUCTS SHOULD NOT BE INSTALLED OR USED BY PERSONS NOT KNOWLEDGEABLE OF THE HAZARDS ASSOCIATED WITH THE USE OF GASEOUS FUELS.